



BLT-E
ELECTRIC FLOOR MODEL BRAISING PAN WITH
MANUAL TILT
INSTALLATION – OPERATION – MAINTENANCE



BLODGETT OVEN COMPANY

www.blodgett.com
44 Lakeside Avenue, Burlington, Vermont 05401 USA Telephone (800) 331-5842, (802) 860-3700 Fax: (802) 864-0183

S00070 Rev A (5/04)

IMPORTANT NOTES FOR INSTALLATION AND OPERATION

It is recommended that this manual be read thoroughly and that all instructions be followed carefully. This manual should be retained for future reference.



This is the safety alert symbol. It is used to alert you to potential personal injury hazards. Obey all safety messages that follow this symbol to avoid possible injury or death.



WARNING: Improper installation, operation, adjustment, alteration, service or maintenance can cause property damage, injury or death. Read the installation, operating and maintenance instructions thoroughly before installing, operating or servicing this equipment.

ADEQUATE CLEARANCES MUST BE MAINTAINED FOR SAFE AND PROPER OPERATION.

THIS MANUAL SHOULD BE RETAINED FOR FUTURE REFERENCE.

INTENDED FOR COMMERCIAL USE ONLY. NOT FOR HOUSEHOLD USE.

TABLE OF CONTENTS

DESCRIPTION	PAGE
Service Connections	4
Installation and Service Connections	5
1.0 Installation Instructions	5
2.0 Operation	6
3.0 Cooking Guidelines	7
4.0 Cleaning Instructions	11
5.0 Troubleshooting	12
6.0 Periodic Maintenance	12

SERVICE CONNECTIONS

 Electrical connection to be as specified on data plate.

ELECTRICAL CHARACTERISTICS

MODEL	kW	PHASE	AMPS PER LINE						
			208V	220V	240V	380V	415V	480V	600V
BLT-30E	18	3	50.0	47.2	43.3	27.3	25.0	21.6	17.3
BLT-40E	27	3	75.0	70.9	65.0	41.0	37.6	32.5	26.0

DIMENSIONS

MODEL	CAPACITY	UNITS	A	B	C	D	E	F	G
BLT-30E	30 U.S. gal.	inches	50 1/2	33 3/4	23 1/8	43 5/8	8 3/4	11	66
	114 litres	mm	1283	857	587	1108	222	279	1676
BLT-40E	40 U.S. gal.	inches	66 1/2	49 1/2	24	59 1/2	8 3/4	11	67
	152 litres	mm	1689	1257	610	1511	222	279	1702

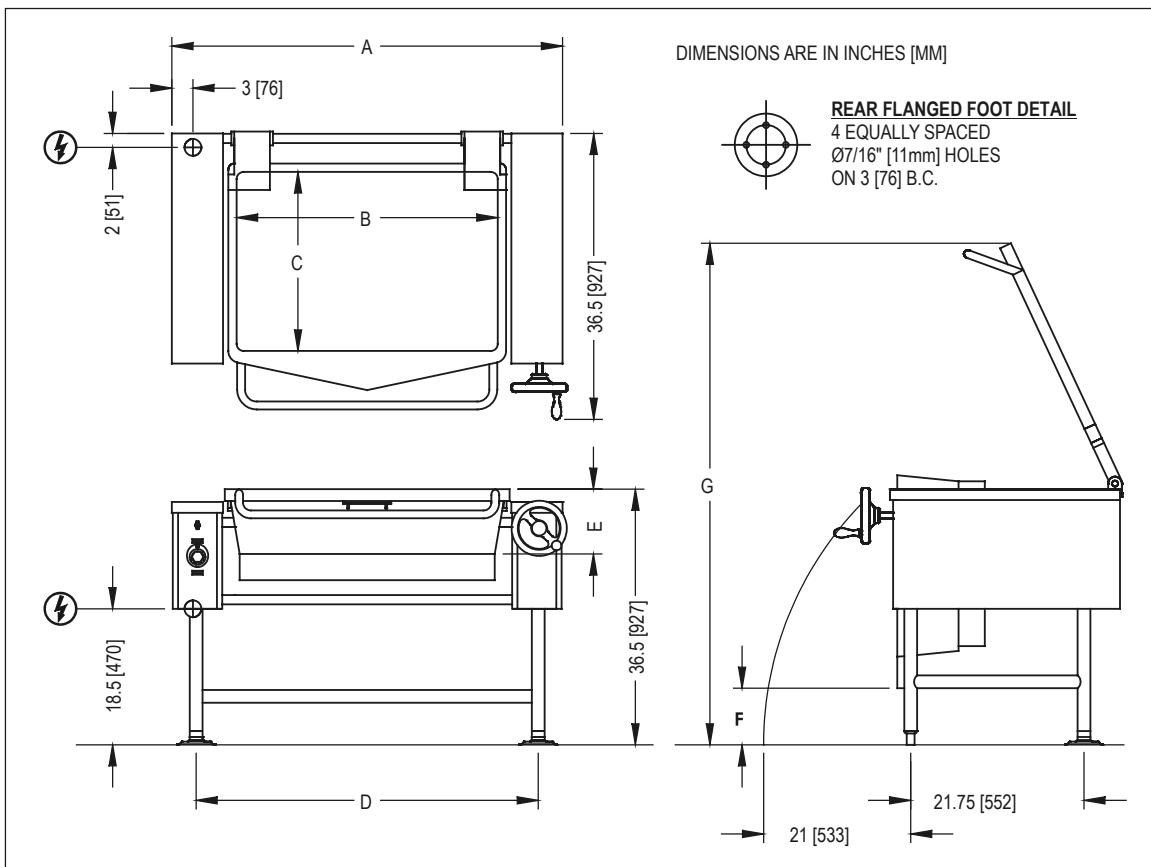

INSTALLATION AND SERVICE CONNECTIONS

1.0 INSTALLATION INSTRUCTIONS

Set braising pan in place, level appliance using spirit level. Mark hole locations on floor through anchoring holes provided in flanged adjustable feet.

Remove appliance and drill holes in locations marked on floor and insert proper anchoring devices.

Re-level the appliance, leveling the unit left to right and front to back.

Bolt and anchor appliance securely to the floor. Seal bolts and flanged feet with Silastic or equivalent compound.

SERVICE CONNECTIONS

All internal wiring for the skillet is complete.

Make service connections as indicated on page 4.

This must be a waterproof connection from incoming lines.

Ground skillet to terminal provided in control housing. A wiring diagram is provided and is located inside the control cover panel.

If faucet is provided connect water supply and check for proper operation.

2.0 OPERATION

Ensure the power supply is connected to unit and that circuit breakers are on.

Tilt braising pan to ascertain that it moves easily. Turn handle as far as it will go and return to upright position.

Turn power switch "ON". Preheat braising pan and allow it to cycle thus equalizing heat across entire pan surface. Cooking should be done at various temperature settings on the dial as determined by the user. Cooking will occur faster with the cover down.

At the end of cooking turn thermostat to "OFF", turn power switch "OFF", remove product.



WARNING: Never tilt pan with cover down



CAUTION: The appliance and its parts are hot. Use care when operating, cleaning and servicing the appliance.

3.0 COOKING GUIDELINES

The guidelines given below are suggested quantities, temperature settings, and **estimated** numbers of orders per load and per hour. When two temperatures are given, the first is to start the product, and the second to finish the product.

The following temperatures should be used:

	<u>Temperature (°F)</u>
Simmering	200 Maximum
Sautéing	225 - 275
Searing	300 - 350
Frying	325 - 375
Grilling	350 - 450

<u>ITEM</u>	<u>PORTION</u>	<u>TEMP (F)</u>	<u>BATCH/HR</u>	<u>BLT-30E PER LOAD QTY</u>	<u>BLT-30E PER LOAD PORTIONS</u>	<u>BLT-40E PER LOAD QTY</u>	<u>BLT-40E PER LOAD PORTIONS</u>
BREAKFAST FOODS							
Bacon	3 slices	350	12	2 lbs.	10	3 lbs.	15
Eggs							
- Boiled-Hard	1 egg	225	5	50 eggs	50	75 eggs	75
- Boiled-Soft	1 egg	225	8	50 eggs	50	75 eggs	75
- Fried	1 egg	400	4	30 eggs	30	45 eggs	45
- Poached	1 egg	225	5	36 eggs	36	60 eggs	60
- Scrambled	1-1/2 eggs	300-200	1	18 gal.	720	28 gal.	1100
French Toast	3 slices	450	7	35 slices	12	50 slices	17
Regular Oatmeal	½ cup	250	2	20 lbs. (100 cups)	500	40 lbs. (200 cups)	1000
Pancakes	2 each	400	10	30 ea.	15	50 ea.	25
FISH							
Clams	1 pt.	400	10	10 qts.	20	15 qts.	30
Fish Cakes	2 - 3 oz.	400	5	70 - 3 oz.	35	110 - 3 oz.	55
Haddock Fillet	4 oz.	400	4	60 - 4 oz.	60	90 - 4 oz.	90
Halibut Steak	5 oz.	450	3	60 - 4 oz.	60	90 - 4 oz.	90
Lobster	1 - 1 lb.	350	4	20 - 1 lb.	20	30 - 1 lb.	30
Swordfish	5 oz.	450	3	50 - 5 oz.	50	75 - 5 oz.	75

<u>ITEM</u>	<u>PORTION</u>	<u>TEMP (F)</u>	<u>BATCH/HR</u>	<u>BLT-30E PER LOAD</u>		<u>BLT-40E PER LOAD</u>	
				<u>QTY</u>	<u>PORTIONS</u>	<u>QTY</u>	<u>PORTIONS</u>
SAUCES, GRAVIES, SOUPS							
Brown Gravy	1 oz.	350 - 200	2	18 gal.	2300	35 gal.	4500
Cream Sauce	2 oz.	250 - 175	1	18 gal.	1150	35 gal.	2250
Cream Soup	6 oz.	200	1	18 gal.	375	35 gal.	725
French Onion Soup	6 oz.	225	1	18 gal.	350	35 gal.	700
Meat Sauce	4 oz.	350 - 200	1	18 gal.	575	35 gal.	1100
VEGETABLES							
<u>CANNED</u>	3 oz.	400	6	30 lbs.	125	45 lbs.	200
<u>FRESH</u>							
Beans, Wax, Green	3 oz.	400	3	25 lbs.	125	50 lbs.	250
Beets	3 oz.	400	1	30 lbs.	125	60 lbs.	300
Broccoli	3 oz.	400	3	25 lbs.	125	40 lbs.	200
Cabbage	3 oz.	400	5	20 lbs.	80	30 lbs.	125
Carrots	3 oz.	400	2	35 lbs.	150	70 lbs.	300
Cauliflower	3 oz.	250	5	15 lbs.	75	25 lbs.	125
Corn	1 ear	400	8	50 ears	50	75 ears	75
Potatoes	3 oz.	400	2	40 lbs.	200	60 lbs.	300
Spinach	4 oz.	250	10	6 lbs.	25	9 lbs.	35
Turnips	4 oz.	400	2	20 lbs.	100	30 lbs.	150
<u>FROZEN</u>							
Beans, French Green	3 oz.	400	6	15 lbs.	60	22-1/2 lbs.	90
Lima Beans	3 oz.	250	4	15 lbs.	60	22-1/2 lbs.	90
Broccoli	3 oz.	400	8	12 lbs.	50	18 lbs.	75
Sliced Carrots	3 oz.	250	6	15 lbs.	60	22-1/2 lbs.	90
Small Whole Carrots	3 oz.	250	3	15 lbs.	50	22-1/2 lbs.	90
Corn	3 oz.	250	18	15 lbs.	50	22-1/2 lbs.	90
Small Whole Onions	3 oz.	250	7	15 lbs.	50	22-1/2 lbs.	90
Peas	3 oz.	400	10	15 lbs.	75	22-1/2 lbs.	110
Spinach	3 oz.	400	3	15 lbs.	75	22-1/2 lbs.	110

<u>ITEM</u>	<u>PORTION</u>	<u>TEMP (F)</u>	<u>BATCH/HR</u>	<u>BLT-30E PER LOAD</u>		<u>BLT-40E PER LOAD</u>	
				<u>QTY</u>	<u>PORTIONS</u>	<u>QTY</u>	<u>PORTIONS</u>
DESSERTS, PUDDINGS, SWEET SAUCES							
Butterscotch Sauce	1 oz.	200	1	18 gal.	2300	35 gal.	4500
Cherry Cobbler	3 oz.	200	1	18 gal.	750	35 gal.	1500
Chocolate Sauce	1 oz.	200	1	18 gal.	2300	35 gal.	4500
Cornstarch Pudding	4 oz.	200	1	18 gal.	575	35 gal.	1100
Fruit Gelatin	3 oz.	250	2	18 gal.	750	35 gal.	1500
MEAT-POULTRY							
Bacon	3 slices	350	12	2 lbs.	10	3 lbs.	15
<u>BEEF</u>							
Amer. Chop Suey	6 oz.	400 - 225	2	18 gal.	350	35 gal.	700
Beef Stew	8 oz.	300	-	18 gal.	280	35 gal.	560
Corned Beef Hash	5 oz.	400	5	16 lbs.	50	25 lbs.	75
Cheeseburger	3 oz.	300	12	7 lbs.	35	10 lbs.	50
Hamburger	3 oz.	300	15	7 lbs.	35	10 lbs.	50
Meatballs	1 oz.	400-225	3	12-1/2 lbs.	65	18 lbs.	100
Pot Roast	2 oz.	350-200		120 lbs.	500	180 lbs.	750
Salisbury Steak	5 oz.	400	3	16 lbs.	50	24 lbs.	75
Sirloin Steak	6 oz.	400	5	15 lbs.	40	22-1/2 lbs.	60
Swiss Steak	4 oz.	300-200	1	25 lbs.	110	40 lbs.	160
<u>CHICKEN</u>							
Pan Fried	2-1/4's	350	3	50 pieces	25	80 pieces	40
Whole	2 oz.	350-200		16 - 5 lbs.	200	24-5 lbs.	265
<u>FRANKFURTERS</u>							
Grilled	2 oz.	300	8	22 lbs.	176	33 lbs.	264
Boiled	2 oz.	250	12	16 lbs.	128	25 lbs.	200
<u>PORK</u>							
Ham Steak	3 oz.	400	8	10 lbs.	50	15 lbs.	75
Sausage Links	3 links	350	7	30 lbs.	120	45 lbs.	180
Pork Chops	5 oz.	350	4	15 lbs.	50	25 lbs.	75

<u>ITEM</u>	<u>PORTION</u>	<u>TEMP (F)</u>	<u>BATCH/HR</u>	<u>BLT-30E PER LOAD</u>		<u>BLT-40E PER LOAD</u>	
				<u>QTY</u>	<u>PORTIONS</u>	<u>QTY</u>	<u>PORTIONS</u>
MEAT-POULTRY (continued)							
<u>TURKEY</u>							
Off Carcass	2 oz.	400-200	–	3 26-30 lbs.	200	4 26-30 lbs.	275
On Carcass	2 oz.	400-200	–	4 16-20 lbs.	175	6 16-20 lbs.	265
MISCELLANEOUS							
Grilled Cheese Sandwich	1 sandwich	400	8	35 sandwiches	35	50 sand.	50
Macaroni & Cheese	8 oz.	200	2	18 gal.	300	35 gal.	525
Rice	4 oz.	350-225	1	20 lbs. raw	320	40 lbs. raw	650
Spaghetti	4 oz.	350-225	2	8 lbs. raw	200	12 lbs. raw	300

4.0 CLEANING INSTRUCTIONS



WARNING: Disconnect the power supply to the appliance before cleaning or servicing.

The electric tilting braising pan should be cleansed after each use.

Soak cooking surface with water and a mild soap to remove any food stuck to surface.

Wash entire unit surface with mild detergent and water. Rinse entire unit and dry.



WARNING: Never spray water into electrical controls or components.

Check that pour spout, strainer, cover and sides of unit are cleansed as well as cooking surface.

5.0 TROUBLESHOOTING

Unit will not operate:

1. Power supply not "ON".
2. Pan not in down position.
3. Defective thermostat or elements.

Pan difficult to tilt:

1. Unit not level.
2. Thrust bearings worn out.
3. Dirt in bearings causing it to bind.
4. Shaft bent.

6.0 PERIODIC MAINTENANCE

1. Grease pivot bearings via lubricating nipple as required. Use Petro-Canada type 0G-2 or equivalent.
2. Check that screws in element terminals are not loose. Loose connections may cause arcing and burn off connection causing element failure.